

BRIEF INFORMATION

Vacuum pumps and pressure sensor

- Electrical vacuum pumps to support or independently generate the vacuum for the pneumatic brake booster system
- Applicable for all engine concepts, also for electric motors and hybrid drives
- HELLA is the market leader and has over 10 years of experience in developing and manufacturing electrical vacuum pumps

PRODUCT FEATURES

Application

Under certain driving conditions or depending on the engine layout, no vacuum or an insufficient vacuum is supplied to the brake booster through the intake manifold of the internal combustion engine. The UP 28 variant can support the system by generating an additional vacuum (support application). The UP 5.0 can provide the pneumatic vacuum supply as a "stand-alone" system. For this, the pump acts as the sole vacuum source and ensures an adequate supply for the brake booster and any auxiliary consumers.

DESIGN AND FUNCTION

ROTARY VANE COMPRESSOR PRINCIPLE

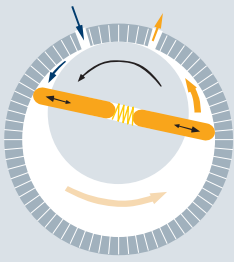

The vacuum pumps' function is based on the rotary vane compressor principle. The pump contains a rotor that is off-centre to the pump chamber. The blades set in the rotor slide along the interior wall of the pump chamber.

The volume enclosed by the blades is continuously compressed by rotation. This change in the chamber volume generates a vacuum causing air to be sucked in by the brake booster through the vacuum pump via the brake system's pneumatic line system.

SPECIAL FEATURES

- Engine-independent vacuum support
- Flexible installation location
- Dry-running system (no connection to the lubricating oil circuit required and maintenance-free)
- Further use of conventional brake systems for alternative drive systems, such as hybrid and electric drives
- Reduction of energy consumption due to demand-based use
- Support for complying with legal requirements to reduce pollutant emissions

Technical details

	UP 28	UP 5.0
Product photo		
Description	<ul style="list-style-type: none"> → Rotor and pump chamber eccentrically fixed → 5-wing technology → Typical for support applications 	<ul style="list-style-type: none"> → Rotor with 8 blades, optimised shape of pump chamber → Plastic silencers with specific shape for noise improvement → Typical for "stand-alone" applications
Rated voltage	13.5 V	13 V
Average current consumption between thresholds	< 10 A	16 A
Service life	600 h	1,500 h
Maximum vacuum	86 % (≥ 88 % typical)	≥ 90 %
Time to reduce by 50 % of ambient pressure	≤ 5.5 s	≤ 3.0 s
Time to reduce by 70 % of ambient pressure	≤ 11 s	≤ 6.0 s
Booster size	3.2 l	5 l
Operating temperature	-40 to +100 °C	-40 to +120 °C
Acoustics	< 70 db (A)	< 73 db (A)
Protection class	IP 6K9K	IP 6K9K

Technical drawing

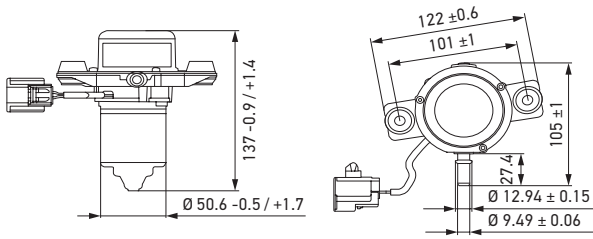

UP 28 - with engine compartment plug

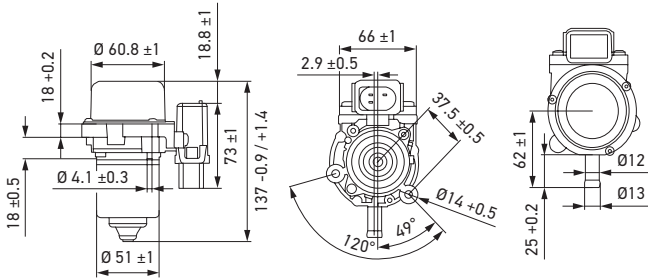

UP 28 - with relay box

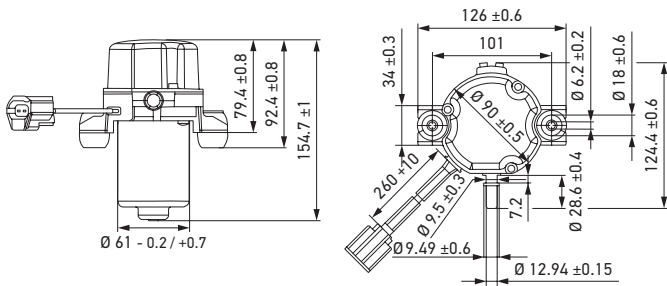

UP 5.0 - with engine compartment plug

Pin assignment



- 1 Engine terminal "+"
- 2 Engine terminal "-"

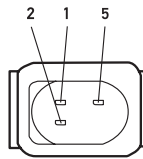

- 1 Terminal 31 -
- 2 Signal low-active (engine control unit)
- 5 Terminal 30+

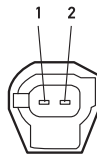

- 1 Engine terminal "+"
- 2 Engine terminal "-"

Comparison of vacuum curves UP 28 ~ UP 5.0

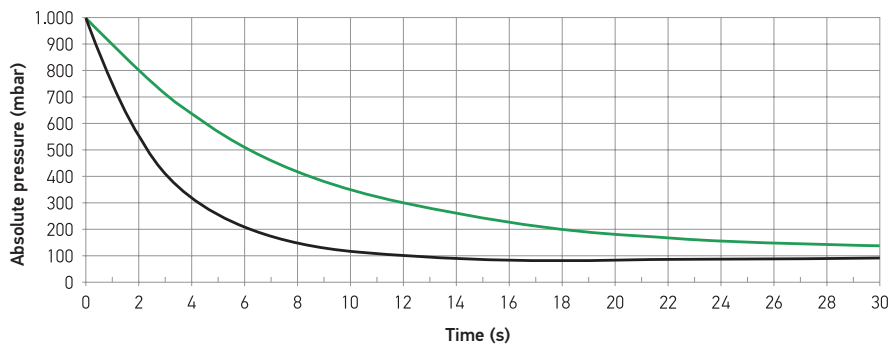

- UP 28
- UP 5.0

Booster volume = 4 L

Voltage = 13 V

Temperature = RT

COMPARISON of support and "stand-alone" application

TECHNICAL DETAILS

Support application UP 28

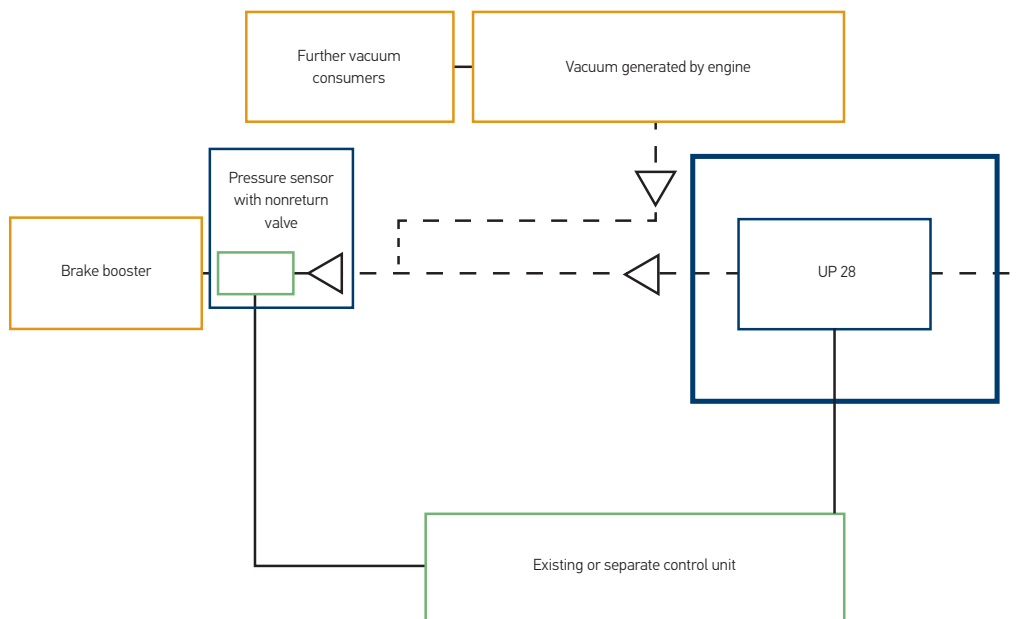

"Stand-alone" application UP 5.0

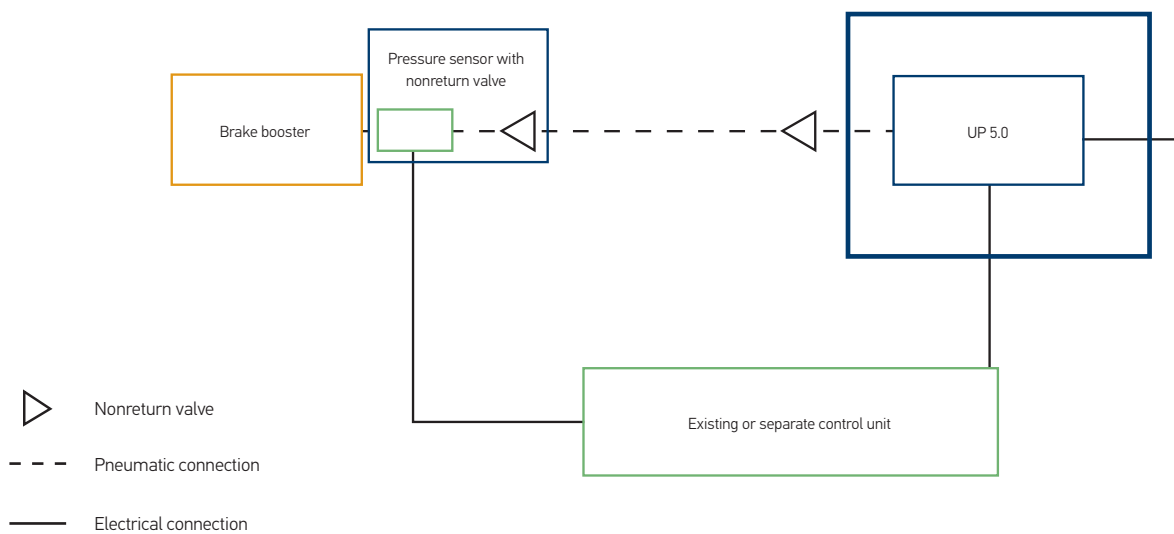

Programme overview



UP 28 – with relay box

1 pc. **8TG 008 570-021**
 6 pcs. **8TG 008 570-027**



UP 28 - with engine compartment plug

1 pc. **8TG 009 428-081**
 6 pcs. **8TG 009 428-087**



UP 5.0 – with engine compartment plug

1 pc. **8TG 012 377-701**
 10 pcs. **8TG 012 377-707**

PRESSURE SENSOR WITH NONRETURN VALVE

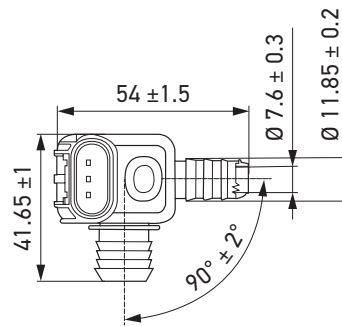

1 pc.	6PP 233 518-011
72 pcs.	6PP 233 518-017

Product features

- Can be fully integrated into the vacuum system of the brake boost
- Compact design
- Simple mechanical connection

Application

This pressure sensor is used for measuring the vacuum. It is suitable for applications such as monitoring the vacuum circuit of the brake booster. It can be integrated directly into the vacuum line.

Design and function

This pressure sensor sends its output signal to the control unit of the brake system, which in turn controls the switch-on and switch-off points of the electrical vacuum pump (UP 28 and UP 5.0). This ensures that the hydraulic brake system is permanently supported by the brake booster in all situations during the braking process. The signal voltage of the sensor is between 0.4 and 4.8 V, analogue.

Application examples

All vehicles with a conventional hydraulic brake system and support via a brake booster that is supplied by the HELLA vacuum pump.

Technical data

Operating voltage	4.5 V to 5.5 V
Rated voltage	5 V
Overvoltage protection	min. -14 V and max. +16 V
Reverse-polarity voltage at room temperature	14 V
Current consumption	15 mA
Max. terminal voltage	4.8 V
Min. terminal voltage	0.4 V
Voltage range of linear output signal	0.5 V to 4.5 V
Output signal voltage at 0 hPa differential pressure	0.5 V ± 65 mV at -40 °C to 130 °C
Output signal voltage at -1000 hPa differential pressure	4.5 V ± 65 mV at -40 °C to 130 °C
Operating temperature	-40 °C to +130 °C
Storage temperature	-40 °C to +100 °C
Protection class	IP 6K9K
Accuracy of pressure measurement	±16.5 hPa at -40 °C to 130 °C

Pin assignment

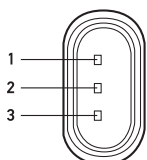

Pin 1: Output signal voltage
Pin 2: Ground
Pin 3: Supply voltage

Transfer function vacuum sensor with power supply $U_s = 5 V \pm 0.25 V$

